

Cleco®

**Durable.
Economical.
Low Maintenance.**

Unbeatable Performance

We are constantly improving our products to guarantee you ideal productivity. The new Cleco H-Series pulse tools combine legendary durability with unmatched repeatability so that you will be able to complete every joint quickly and reliably.

■ **Broad Tool Selection**

With a variety of shut-off and non-shut-off pulse tools to choose from you are sure to find just the right Cleco pulse tool for the job.



High Precision Shut-Off

mechanism ranges close to the characteristics of an electric tool at a tolerance of +/- 10% at Six Sigma.

Efficient 3-Chamber Air Motor

- Speed governor
- Reduces your tightening time with increased torque and a usable high-end dynamic.
- Unique design reduces blade wear.
- Less vibration for increased user comfort
- Reduced air consumption



3-Chamber Motor Housing

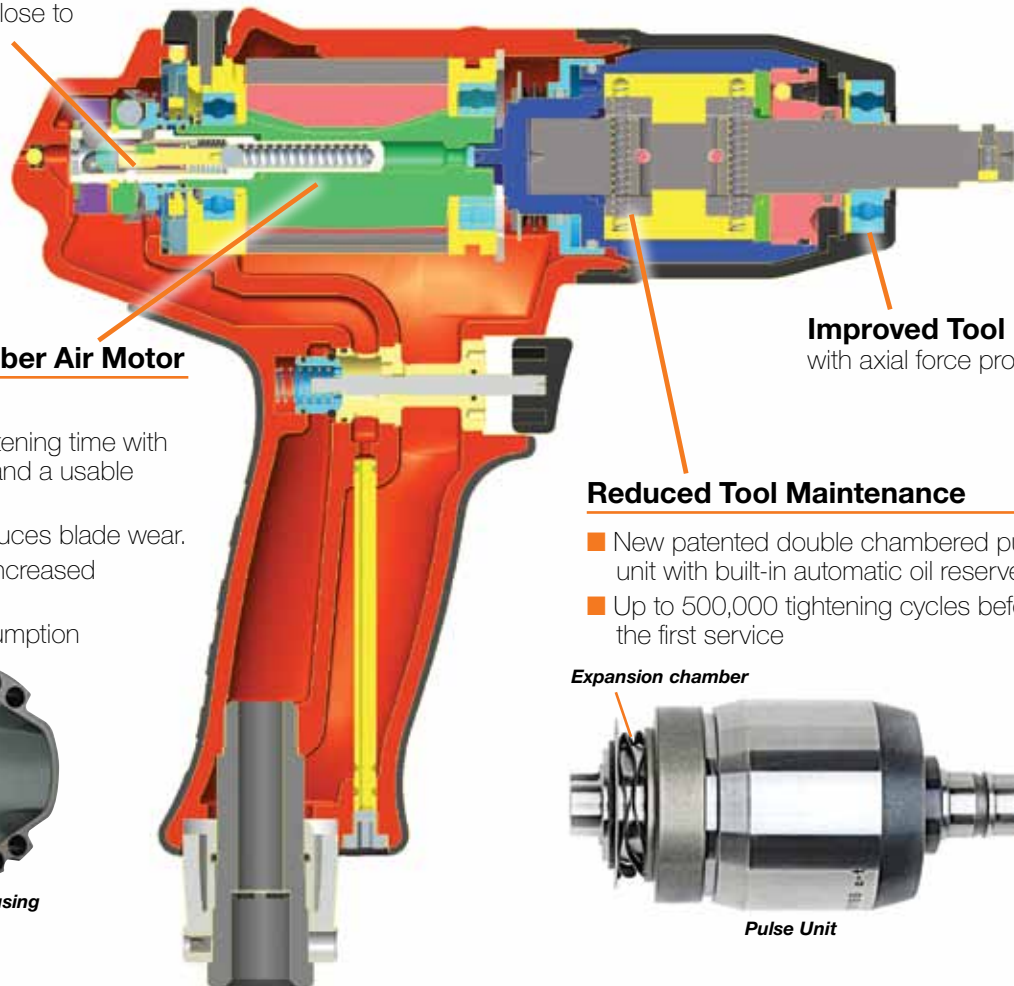

Improved Tool End
with axial force protection

Reduced Tool Maintenance

- New patented double chambered pulse unit with built-in automatic oil reserve
- Up to 500,000 tightening cycles before the first service

Expansion chamber



Pulse Unit

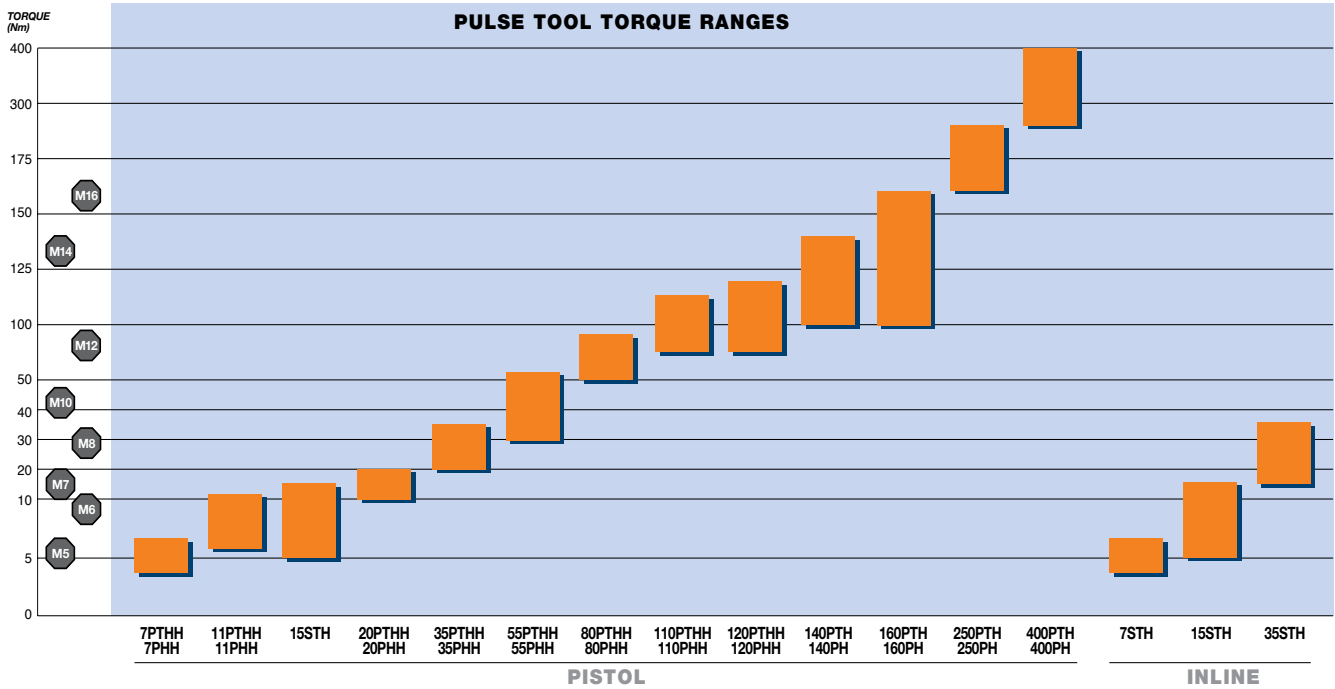

Low Noise Levels

Noise levels of these tools are well below standard air tools for an operator-friendly environment. There is no loud metallic hammering under load.

Ships Ready For Error Proofing

- Works with existing TVP torque verifier
- Located near air inlet to maximize ergonomics



Standard air signal indicating tool shutoff for use with Cleco TVP Error Proofing System.

Easy Set-Up

- Insert 2mm hex into rear port of tool
- Positive stops in both directions to prevent loss and/or damage



Adjustable Motor Speed

- Easily adjustable motor speed to insure accuracy on hard joints
- Can be locked in place to prevent accidental adjustment



Pulse Nutrunners

Hydraulic Pulse Shut-Off & Non Shut-Off



H-Series PTH

Torque Range: 4 - 120 Nm
3.0 - 88.8 Ft. Lbs
Bolt Size: M5 - M12
#10 - 1/2"

- Inertia shut-off
- Motor governor equipped
- External torque adjustment
- External speed control
- Torque signal port
- Adjustable pulse unit volume simplifies maintenance
- Market-leading repeatability
- Reversible
- Oilless blades 



C-Series PTHC & PTHFC

Torque Range: 100 - 400 Nm
74 - 295 Ft. Lbs
Bolt Size: M12 - M20
1/2" - 3/4"

- Hydraulic pulse shut-off
- Motor governor equipped
- External torque adjustment
- External speed control
- Reversible
- Oilless blades 
- Torque signal port



C-Series STHFC & STHF

Torque Range: 2.6 - 35 Nm
1.9 - 26 Ft. Lbs
Bolt Size: M5 - M8
#10 - 3/8"

- Hydraulic pulse shut-off
- Motor governor equipped
- External torque adjustment
- External speed control
- Reversible
- Oilless blades 
- Torque signal port



Model Number Nomenclature

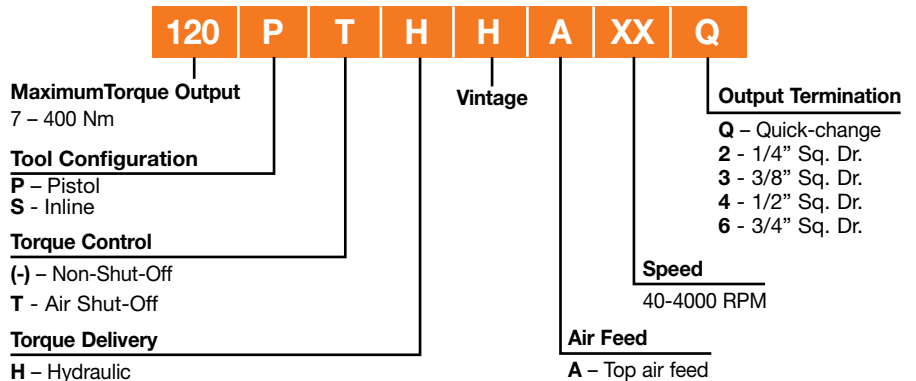

| | Model Number | Drive Type | Torque Range | | Free Speed | Weight | | Air Consumption | | | |
|----------------------------|--|-------------|--------------|---------|------------|--------|------|-----------------|-----------|------|--|
| | | | Ft.Lbs. | Nm | RPM | lbs. | kg | NPT | Hose I.D. | SCFM | |
| S H U T O F | H-Series – Pistol Grip – Shut-Off Models | | | | | | | | | | |
| | 7PTHH352 | 1/4" Sq.Dr. | 3.0-5.1 | 4-7 | 3500 | 1.74 | 0.79 | 1/4" | 3/8" | 7.06 | |
| | 7PTHH35Q | 1/4" QC | 3.0-5.1 | 4-7 | 3500 | 1.74 | 0.79 | 1/4" | 3/8" | 7.06 | |
| | 11PTHH352 | 1/4" Sq.Dr. | 4.4-8.1 | 6-11 | 3500 | 1.81 | 0.82 | 1/4" | 3/8" | 7.06 | |
| | 11PTHH35Q | 1/4" QC | 4.4-8.1 | 6-11 | 3500 | 1.87 | 0.85 | 1/4" | 3/8" | 7.06 | |
| | 11PTHH353* | 3/8" Sq.Dr. | 4.4-8.1 | 6-11 | 3500 | 1.83 | 0.83 | 1/4" | 3/8" | 7.06 | |
| | 20PTHH40Q | 1/4" QC | 7.4-14.7 | 10-20 | 4000 | 1.92 | 0.87 | 1/4" | 1/2" | 8.7 | |
| | 20PTHH403* | 3/8" Sq.Dr. | 7.4-14.7 | 10-20 | 4000 | 1.90 | 0.86 | 1/4" | 1/2" | 8.7 | |
| | 35PTHH40Q | 1/4" QC | 14.8-25.8 | 20-35 | 4000 | 2.31 | 1.05 | 1/4" | 1/2" | 15.9 | |
| | 35PTHH403* | 3/8" Sq.Dr. | 14.8-25.8 | 20-35 | 4000 | 2.31 | 1.05 | 1/4" | 3/8" | 15.9 | |
| | 55PTHH403* | 3/8" Sq.Dr. | 22.1-40.5 | 30-55 | 4000 | 2.54 | 1.15 | 1/4" | 3/8" | 15.9 | |
| | 80PTHH35Q | 7/16" QC | 36.9-59.0 | 50-80 | 3500 | 3.20 | 1.45 | 1/4" | 3/8" | 19.4 | |
| 80PTHH354 | 1/2" Sq.Dr. | 36.9-59.0 | 50-80 | 3500 | 3.10 | 1.40 | 1/4" | 3/8" | 19.4 | | |
| 110PTHH30Q | 7/16" QC | 55.3-81.1 | 75-110 | 3000 | 3.75 | 1.70 | 3/8" | 1/2" | 19.4 | | |
| 120PTHH304 | 1/2" Sq.Dr. | 55.3-88.8 | 75-120 | 3000 | 3.75 | 1.70 | 3/8" | 1/2" | 19.4 | | |
| O F | C-Series – Pistol Grip – Shut-Off Models | | | | | | | | | | |
| | 140PTHFC25Q | 7/16" QC | 74-103 | 100-140 | 2500 | 5.7 | 2.6 | 3/8" | 1/2" | 25.4 | |
| 160PTHFC256 | 3/4" Sq.Dr. | 74-118 | 100-160 | 2500 | 5.7 | 2.6 | 3/8" | 1/2" | 25.4 | | |
| F | C-Series – Pistol Grip – Shut-Off Models – Trigger Throttle | | | | | | | | | | |
| | 250PTHFC226 | 3/4" Sq.Dr. | 118-184 | 160-250 | 2200 | 8.8 | 4.0 | 3/8" | 1/2" | 33.5 | |
| 400PTHFC206 | 3/4" Sq.Dr. | 185-295 | 250-400 | 2000 | 11.7 | 5.3 | 3/8" | 1/2" | 33.5 | | |
| S H U T O F | In-Line – Push-to-Start | | | | | | | | | | |
| | 7STHFA55Q | 1/4" QC | 1.9-4.9 | 2.6-6.6 | 5500 | 1.8 | 0.83 | 1/8" | | 7.0 | |
| | 35STHFA40Q | 7/16" QC | 12-26 | 15-35 | 4000 | 3.1 | 1.4 | 1/4" | 3/8" | 15.9 | |
| | 35STHFA404 | 1/2" Sq.Dr. | 12-26 | 15-35 | 4000 | 2.9 | 1.3 | 1/4" | 3/8" | 15.9 | |
| S H U T O F | C-Series – In-Line – Lever | | | | | | | | | | |
| | 7STHFC55Q | 1/4" QC | 1.9-4.9 | 2.6-6.6 | 5500 | 2.1 | 0.93 | 1/8" | | 7.0 | |
| | 15STHFC40Q | 1/4" QC | 3.6-11 | 5.0-15 | 4000 | 2.4 | 1.1 | 1/4" | 3/8" | 16.5 | |
| | 35STHFC40Q | 7/16" QC | 12-26 | 15-35 | 4000 | 3.3 | 1.5 | 1/4" | 3/8" | 15.9 | |
| | 35STHFC404 | 1/2" Sq.Dr. | 12-26 | 15-35 | 4000 | 3.3 | 1.5 | 1/4" | 3/8" | 15.9 | |
| 15STHC40Q | 1/4" QC | 3.6-11 | 5.0-15 | 3000 | 2.4 | 1.1 | 1/4" | 3/8" | 16.5 | | |

PTHHA=Top Air Inlet

(*) 7/16" Quick Change Chuck available separately as an accessory

General:

Tool performance rated @ 87 psi (6 bar) air pressure.

Standard Equipment:

Suspension bail and torque adjusting wrench.
Torque signal port (pistol grip models only)

Optional Equipment:

Additional accessories: Page 53



Pulse Nutrunners

Hydraulic Pulse Non Shut-Off

Cleco®

H-Series PH Non-Shut-Off

Torque Range: 4 - 120 Nm
2.9 - 88.5 Ft. Lbs
Bolt Size: M5 - M12
#10 - 1/2"

- External speed control
- Reversible
- Oilless blades 



| | Model Number | Drive Type | Torque Range | | Free Speed RPM | Weight | | Air Consumption | | |
|--|--|-------------|--------------|---------|-------------------|--------|------|-----------------|-----------|------|
| | | | Ft.Lbs. | Nm | | lbs. | kg | NPT | Hose I.D. | SCFM |
| N O N S H U T O F F | H-Series – Pistol Grip – Non Shut-Off Models | | | | | | | | | |
| | 7PHH602 | 1/4" Sq.Dr. | 2.9-5.2 | 4-7 | 6000 | 1.70 | 0.77 | 1/4" | 3/8" | 8.7 |
| | 7PHH60Q | 1/4" QC | 2.9-5.2 | 4-7 | 6000 | 1.74 | 0.79 | 1/4" | 3/8" | 8.7 |
| | 11PHH653* | 3/8" Sq.Dr. | 4.4-8.1 | 6-11 | 6500 | 1.74 | 0.79 | 1/4" | 3/8" | 10.5 |
| | 11PHH652 | 1/4" Sq.Dr. | 4.4-8.1 | 6-11 | 6500 | 1.72 | 0.78 | 1/4" | 3/8" | 10.5 |
| | 11PHH65Q | 1/4" QC | 4.4-8.1 | 6-11 | 6500 | 1.76 | 0.80 | 1/4" | 3/8" | 10.5 |
| | 20PHH753* | 3/8" Sq.Dr. | 7.4-14.7 | 10-20 | 7500 | 1.85 | 0.84 | 1/4" | 3/8" | 17.3 |
| | 20PHH75Q | 1/4" QC | 7.4-14.7 | 10-20 | 7500 | 1.90 | 0.86 | 1/4" | 3/8" | 17.3 |
| | 35PHH653* | 3/8" Sq.Dr. | 14.7-25.8 | 20-35 | 6500 | 2.25 | 1.02 | 1/4" | 3/8" | 19.4 |
| | 35PHH65Q | 1/4" QC | 14.7-25.8 | 20-35 | 6500 | 2.29 | 1.03 | 1/4" | 3/8" | 15.9 |
| | 55PHH603* | 3/8" Sq.Dr. | 22.1-40.5 | 30-55 | 6000 | 2.47 | 1.12 | 1/4" | 3/8" | 22.9 |
| | 80PHH604 | 1/2" Sq.Dr. | 36.9-59.0 | 50-80 | 6000 | 3.09 | 1.40 | 1/4" | 3/8" | 26.5 |
| 80PHH60Q | 7/16" QC | 36.9-59.0 | 50-80 | 6000 | 3.13 | 1.41 | 1/4" | 3/8" | 26.5 | |
| 110PHH55Q | 7/16" QC | 55.3-81.1 | 75-110 | 5500 | 3.68 | 1.66 | 3/8" | 1/2" | 30.0 | |
| 120PHH554 | 1/2" Sq.Dr. | 55.3-88.5 | 75-120 | 5500 | 3.64 | 1.65 | 3/8" | 1/2" | 30.0 | |
| | High Torque Pistol Grip – Non-Shut-Off Models | | | | | | | | | |
| | 140PH45Q | 7/16" QC | 74-103 | 100-140 | 4500 | 5.7 | 2.6 | 3/8" | 1/2" | 31.7 |
| | 160PH456 | 3/4" Sq.Dr. | 74-118 | 100-160 | 4500 | 5.7 | 2.6 | 3/8" | 1/2" | 31.7 |
| | 250PHF406 | 3/4" Sq.Dr. | 118-184 | 160-250 | 4000 | 8.6 | 3.9 | 3/8" | 1/2" | 40.6 |
| | 400PHF356 | 3/4" Sq.Dr. | 184-295 | 250-400 | 3500 | 11.5 | 5.2 | 3/8" | 1/2" | 42.3 |

PTHHA=Top Air Inlet

(*) 7/16" Quick Change Chuck available separately as an accessory.

For 7-75 Series Models, small handle can be ordered by substituting "S" for "L" in model number.

General:

Tool performance rated @ 87 psi (6 bar) air pressure.

Standard Equipment:

Suspension bail and torque adjusting wrench.

Optional Equipment:

Additional accessories: Page 53

Rubber Tool Stand



| Part Number | Tool Series |
|---------------------|--|
| 931041 (one piece) | D & H Series 7PTH – 120PTH |
| 930119 (two pieces) | C Series 140/160PTH/PH/ 250PTH / 400PTH |

TVP-100 Torque Signal Kit

Air signal to indicate shut-off.

| Part Number | Tool Series |
|-------------|---|
| 934918 | PTH series pulse tools and vintage shut-off tools only |

7/16" Quick Change Chuck Adapter

| Part Number | Tool Series |
|-------------|--|
| 935472 | To convert 11/20/35/55PTHH/PTHHA/ PHH/PHHA to a Quick-Change chuck |



Vibration Absorber

| Part No. | Fits Model |
|----------|----------------------|
| 935965 | 35/55PTHHA/PHHA |
| 935966 | 80/110/120PTHHA/PHHA |



Hydraulic Filler Unit

| Part Number | | | Tool Series |
|----------------------|------------------|----------------|----------------------|
| Filler Unit Complete | Filler Unit Only | Connector Only | |
| 928477 | | 932072 | 140/160 PTHC../ PH.. |
| 928473 | 928483 | 928485 | 250/400 PTHC../ PH.. |
| | | | 35 STH.. |
| 928475 | | 931663 | 7 STH.. |
| 928474 | | 928486 | 15 STH.. |



Reserve Oil Filling Set

Part No.
936695PT



Hydraulic Oil

| Part Number | Container Size |
|-------------|----------------|
| 539317 | One Quart |



Covers

| Part No. | Fits Model |
|----------|---|
| 937442PT | Protective cover for 7/11/20PTHHA/7/11/20PHHA |
| 937443PT | Protective cover for 35PTHHA/35PHHA |
| 937444PT | Protective cover for 55PTHHA/55PHHA |
| 937445PT | Protective cover for 80PTHHA/80PHHA |
| 937446PT | Protective cover for 110/120PTHHA/110/120PHHA |
| 937447PT | Protective cover for 7/11/20PTHH/7/11/20PHH |
| 937448PT | Protective cover for 35PTHH/35PHH |
| 937449PT | Protective cover for 55PTHH/55PHH |
| 937450PT | Protective cover for 80PTHH/80PHH |
| 937451PT | Protective cover for 110/120PTHH/110/120PHH |

